

# Chevy Power Book

## Corvette Section



This section was reprinted from a late 70's edition of Chevy Power Book. These books were available at Chevrolet dealer's Parts Departments back in the day. The section reprinted here is a guide for preparing the C3 Corvette frame and suspension for road racing. The part numbers are either no longer available, or have been changed. What hasn't changed is the value of the illustrated frame preparation advice.

We agree with Corvette Chief Engineer Tadge Juechter, who put chassis stiffness as by far the greatest component of a car's handling. This frame preparation guide was the state of the art back in the day, and is still good advice today. Anything you can do to stiffen your frame will pay huge dividends in handling.

The frames on these cars were stitch welded hit and miss. If you strike even a new C2 or C3 Corvette frame with a ball peen hammer, it will often sound like you hit a graham cracker. When the frame is fully welded, it sounds more like a bell.

There is really nothing all that 'trick' in making these cars handle like a world class sportscar, but first and foremost you have to have a solid frame.

Alan Sevadjian

## *Corvette Section*

Figure	Description	Page
1	Desired corner braces providing increased lateral stiffness .....	4-1
2	Frame showing the full length arc weld .....	4-1
3	Required frame reinforcement near the steering gear asm. ....	4-2
4	Installation of automatic transmission crossmember .....	4-3
5	Typical roll cage welded to the frame asm. ....	4-3
6	Weld gussets to crossmember and lower control arm brackets .....	4-3
7	Area of frame rail requiring shock absorber clearance .....	4-4
8	Replacement of rubber parts with solid plates and bushings .....	4-4
9	Weld tapping plate to inside of frame rail for stabilizer bar bearing attachments .....	4-5
10	Reinforce welds on stabilizer bar bracket and remove the upper/lower bumpers .....	4-5
11	Proper front and rear vehicle trim heights .....	4-6
12	Reworking rear suspensions control arm .....	4-7
13	Rear suspension strut rod replacements .....	4-7
14	Rear stabilizer bar installation .....	4-8
15	Lapping the clutch disc on the clutch gear to remove any burrs .....	4-8
16	Illustrated transmission identifying the circumferential grooves on input shaft .....	4-9
17	Exploded view of a Muncie Four Speed transmission .....	4-10
18	Polishing front and rear surfaces of counter gear .....	4-11
19	Cone and blocker ring referenced in Step four .....	4-11
20	Blocker ring comparison showing wiping grooves or slot modifications .....	4-11
21	Blocker ring with small "B" imprinted on ring at small end of cone .....	4-11
22	Comparison of a stock washer and a washer with the desired 90° bend .....	4-12
23	Counter gear rear thrust surface .....	4-12
24	Reworked 1st gear, special thrust washer and needle bearing .....	4-12
25	Exploded view of the Corvette positraction .....	4-13
26	Exploded view of the Corvette rear axle carrier assembly .....	4-14
27	Heavy duty suspension instruction sheet for the corvette .....	4-17

# CORVETTE CHASSIS PREPARATION

The following specifications and modifications procedures are intended to assist an individual preparing a Corvette chassis for road course competition such as the I.M.S.A. GT series or S.C.C.A. Trans-Am series.

A thorough knowledge of the current competition rules is essential since the sanctioning organizations rules and interpretation of existing rules frequently change.

These suggested modifications such as frame reinforcements or rewelded seams are only required for off-highway competition activities where abnormal stresses are encountered and for a roll over safety cage installation. It does not imply any inherent structural deficiencies exist in the production components for normal highway usage.

## Frame Preparation

The frame should be removed from the vehicle for thorough cleaning (sand blast preferably) and preparation. Use a new 1969 or later Corvette frame or a good solid non-rusted 1969 or later used frame. A new frame is recommended to minimize the possibility of weakening due to any corrosion encountered during service life. The 1969 and later frames incorporate corner braces (Figure 1) between the differential carrier front crossmember and the frame kickup over the axle shafts which provide increased lateral stiffness at the rear suspension attachments.

All the welds should be full length arc welds, since the production frame has skip welding on it. (Figure 2)

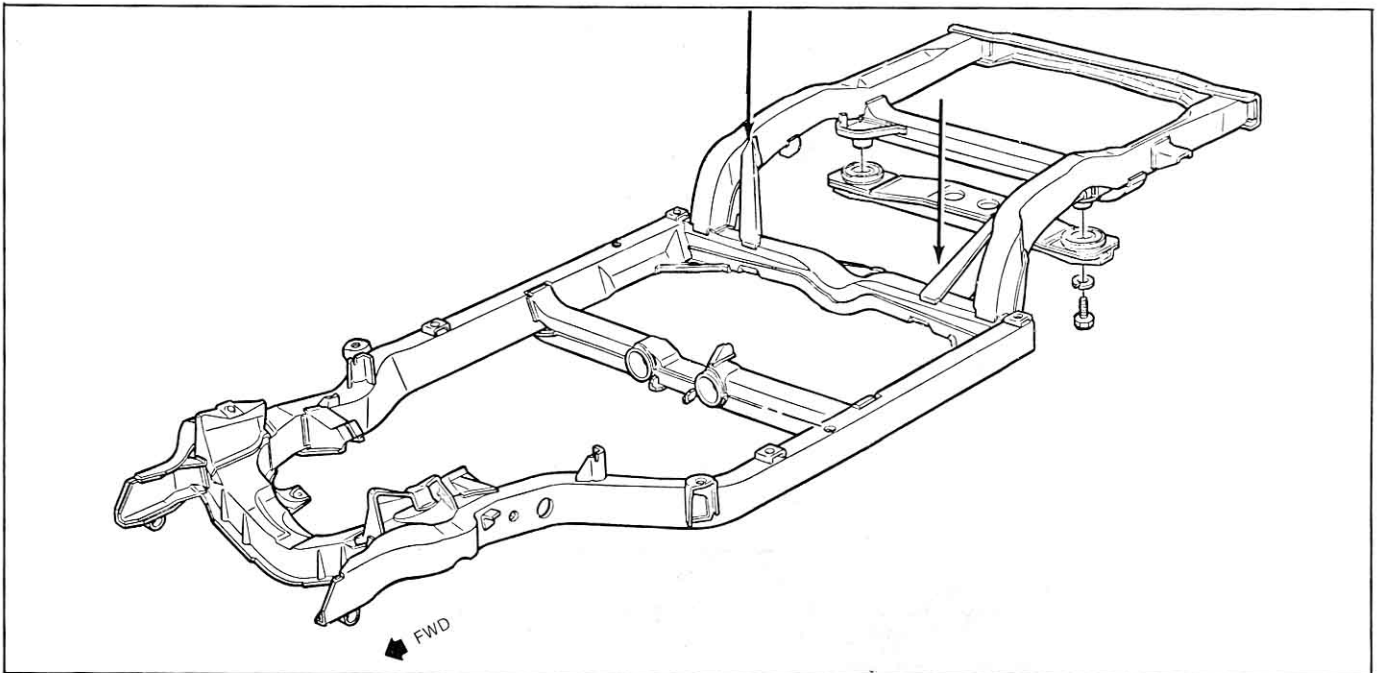

Figure 1 — Desired corner braces providing increased lateral stiffness.

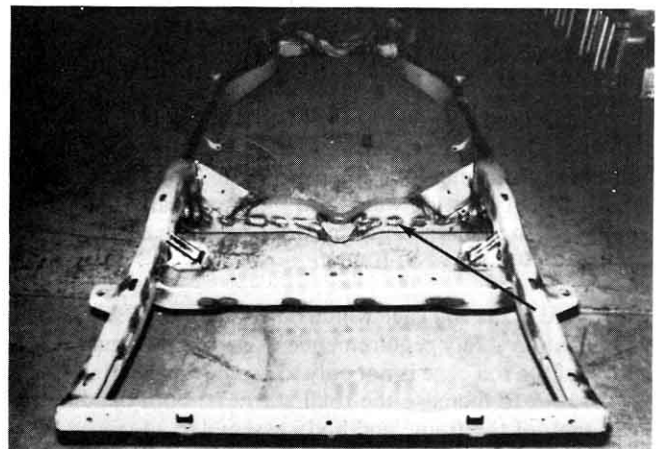
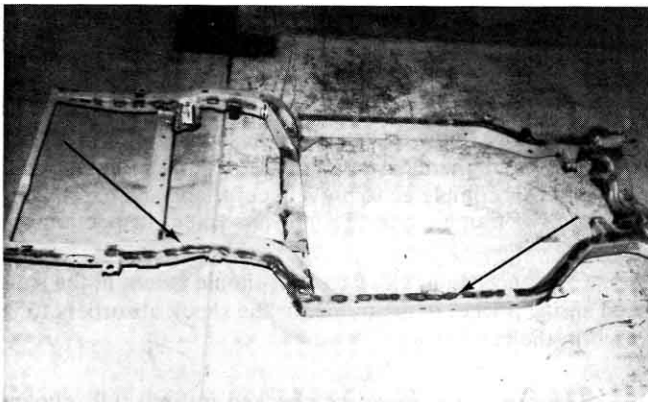

Figure 2 — Frame showing the full length arc weld.

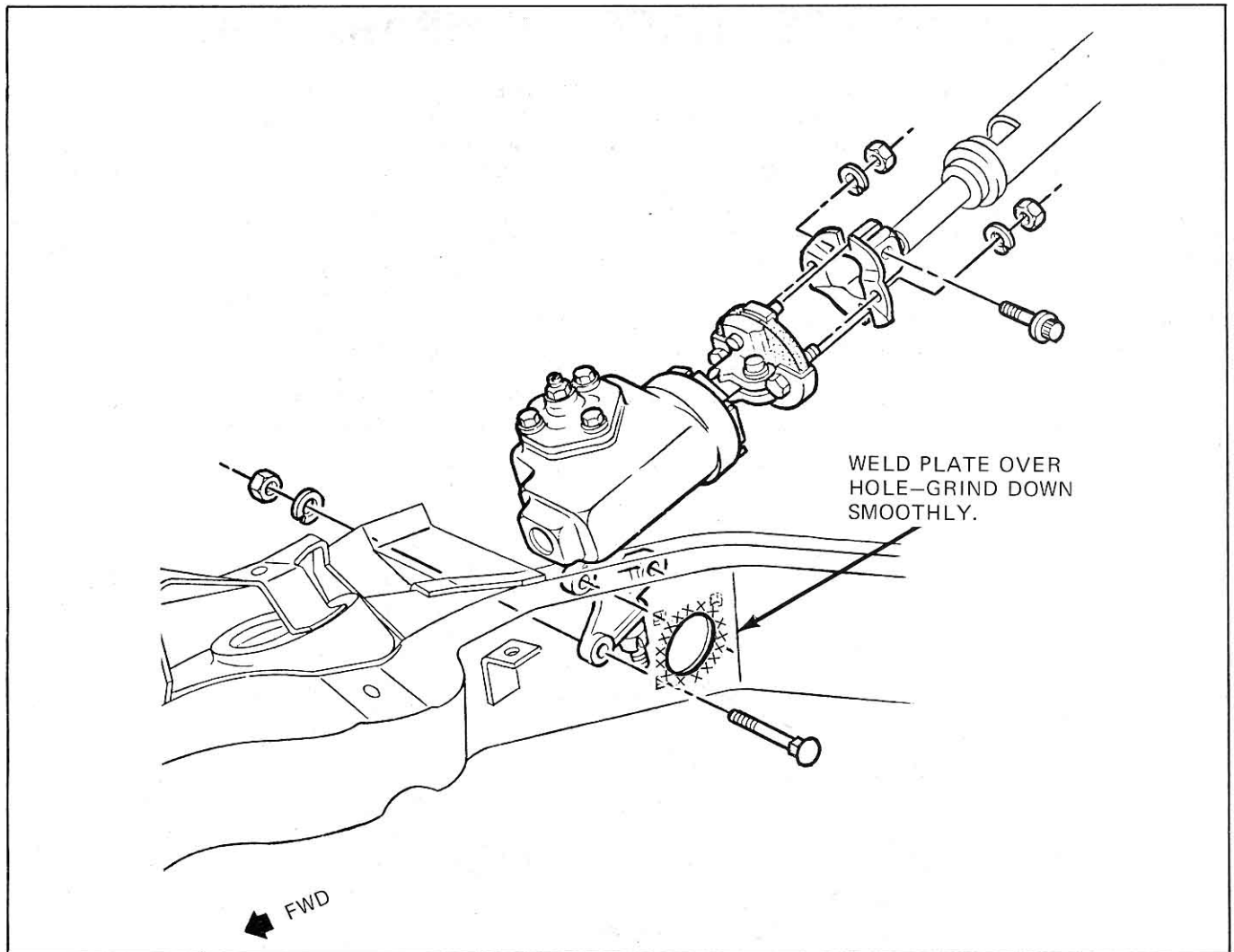

Figure 3 — Required frame reinforcement near the steering gear assembly.

All Manufacturing holes or clearance holes that are not to be used should be plated over and welded. Of particular importance is the hole (Figure 3) near the steering gear in the left side rail which should be filled with a plate, welded and then ground smooth to prevent tire interference.

An automatic transmission frame is recommended because it has a removable crossmember (Figure 4). If an automatic transmission frame is used, the clutch cordon shaft bracket must be welded to the frame, and the manual transmission mounting bracket will have to be adapted to the automatic transmission frame.

Weld in the roll cage which must conform to sanctioning organization safety requirements, as shown in Figure 5. The intent of the roll cage is not only to provide protection for the driver, but to increase the total stiffness, both bending and torsional, of the frame and body assembly.

Therefore, running struts to the front and rear suspension points attachments is mandatory. It is advisable to put

the front suspension tie bar, either welded in or bolted in, between the front upper control arm towers to minimize compliance of the upper control arm attachment points.

Gusseting (Figure 6) should be added to the upper control arm towers and the lower control arm attachment channels in the form of "fish plates".

The entire frame and suspension should be painted with a light colored chemical resistant paint such as epoxy after all welding is completed to prevent corrosion and to facilitate detection of frame cracks during subsequent inspections.

Clearance (Figure 7, page 4-4) should be cut in the front coil spring pocket in the frame for the shock absorbers to be used in the car.

The clearance should be checked in both full rebound and full jounce to prevent possible bending of the shock absorber shaft during suspension travel.

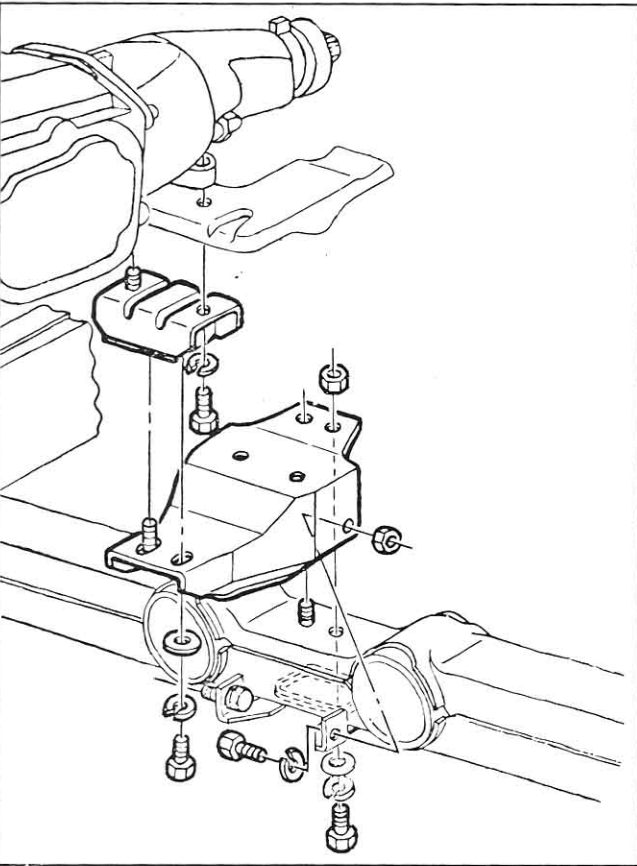

Figure 4 — Installation of automatic transmission crossmember.

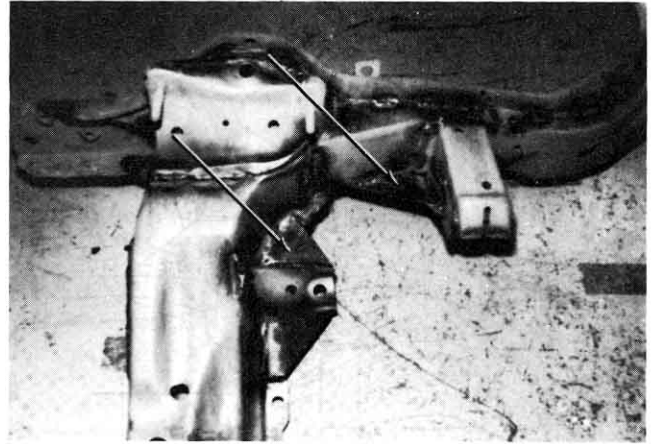

Figure 6 — Weld gussets to crossmembers and lower control arm bracket.

The rear suspension differential carrier mounting crossmember should have the rubber mounts removed and replaced with steel plates. (Figure 8, page 4-4) There is some freedom to adjust the height of these plates to mount the differential carrier further up into the frame. If this is done, the corresponding adjustment should be made in the front differential case attachment.

The frame should be boxed in at the front frame rails forward of the front suspension crossmember over the stabilizer bar attaching points (Figure 9, page 4-5) to provide adequate stiffness for stabilizer bar loads to be imparted to the chassis.

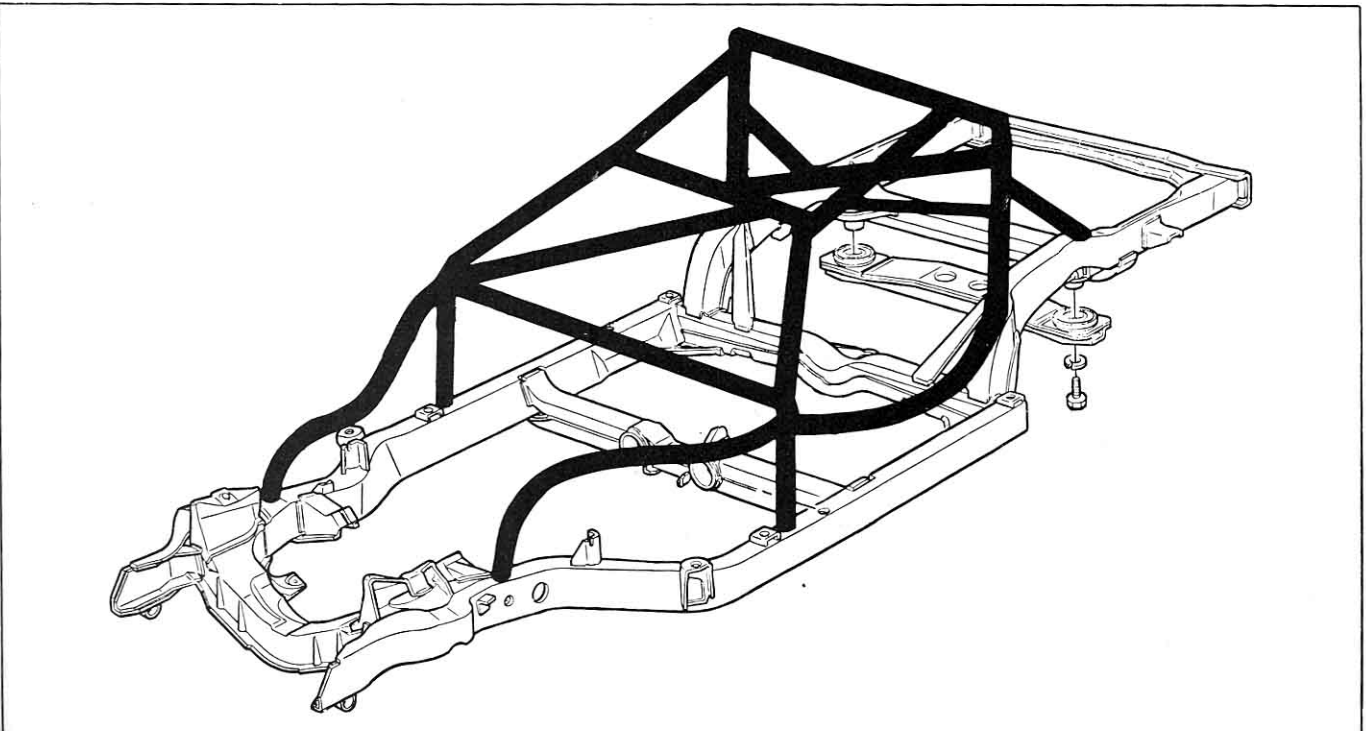

Figure 5 — Typical roll cage welded to the frame assembly.

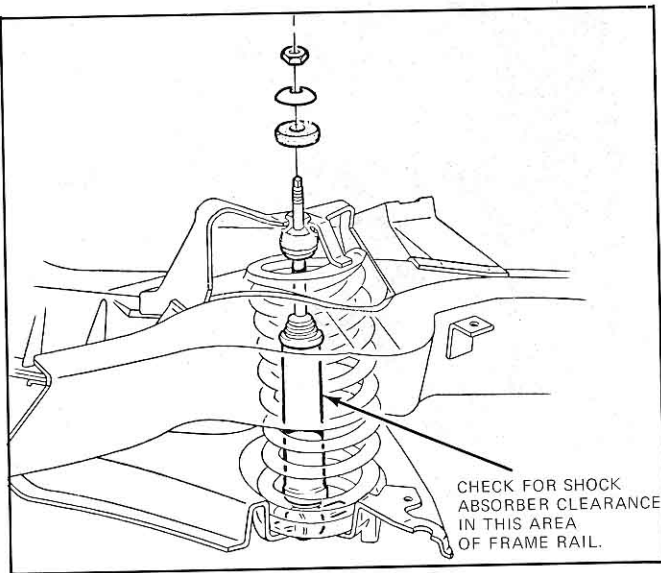

Figure 7 — Area of frame rail requiring shock absorber clearance.

If the rules permit, tire clearance should be provided in the frame rails and the area must be cleaned up with a grinder to prevent sharp surfaces which could possibly cut a tire during cornering. Likewise; at the front the area just aft of the front suspension crossmember should be smoothed up to prevent tire interference.

### Front Suspension

Use production upper and lower control arms. Weld stabilizer bar attachments to lower control arm to reinforce the attachment. (Figure 10)

Replace the rubber control arm bushings with solid bushings either by fabricating replacement bushings from bronze or high density plastic, using commercially available solid bushing kit, or using rod end joints welded onto the arms.

Provide variable caster-camber adjustment at the upper control arm by means of threaded attachments. If production type of attachments are used, then replace shims with

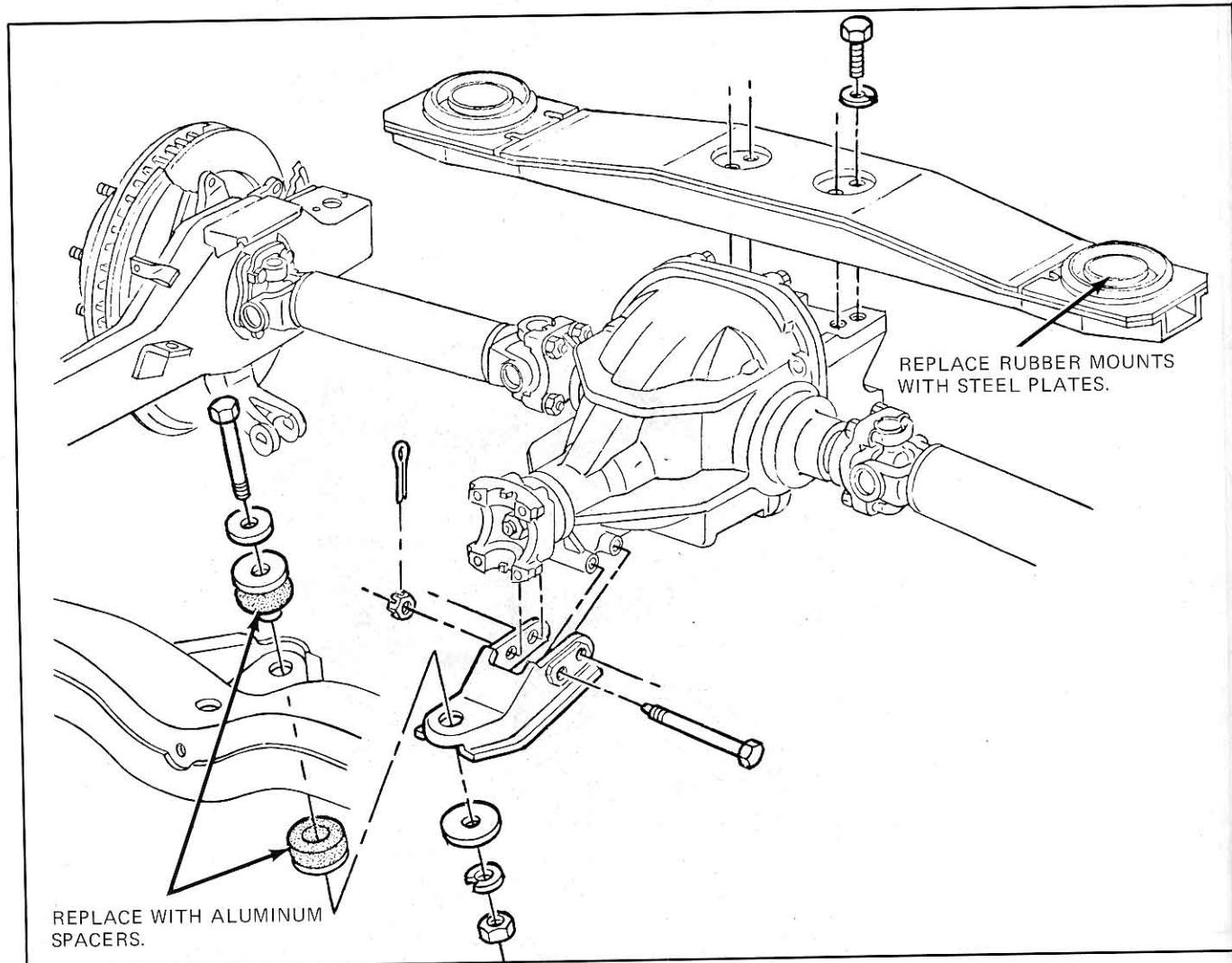

Figure 8 — Replacement of rubber parts with solid plates and bushings.



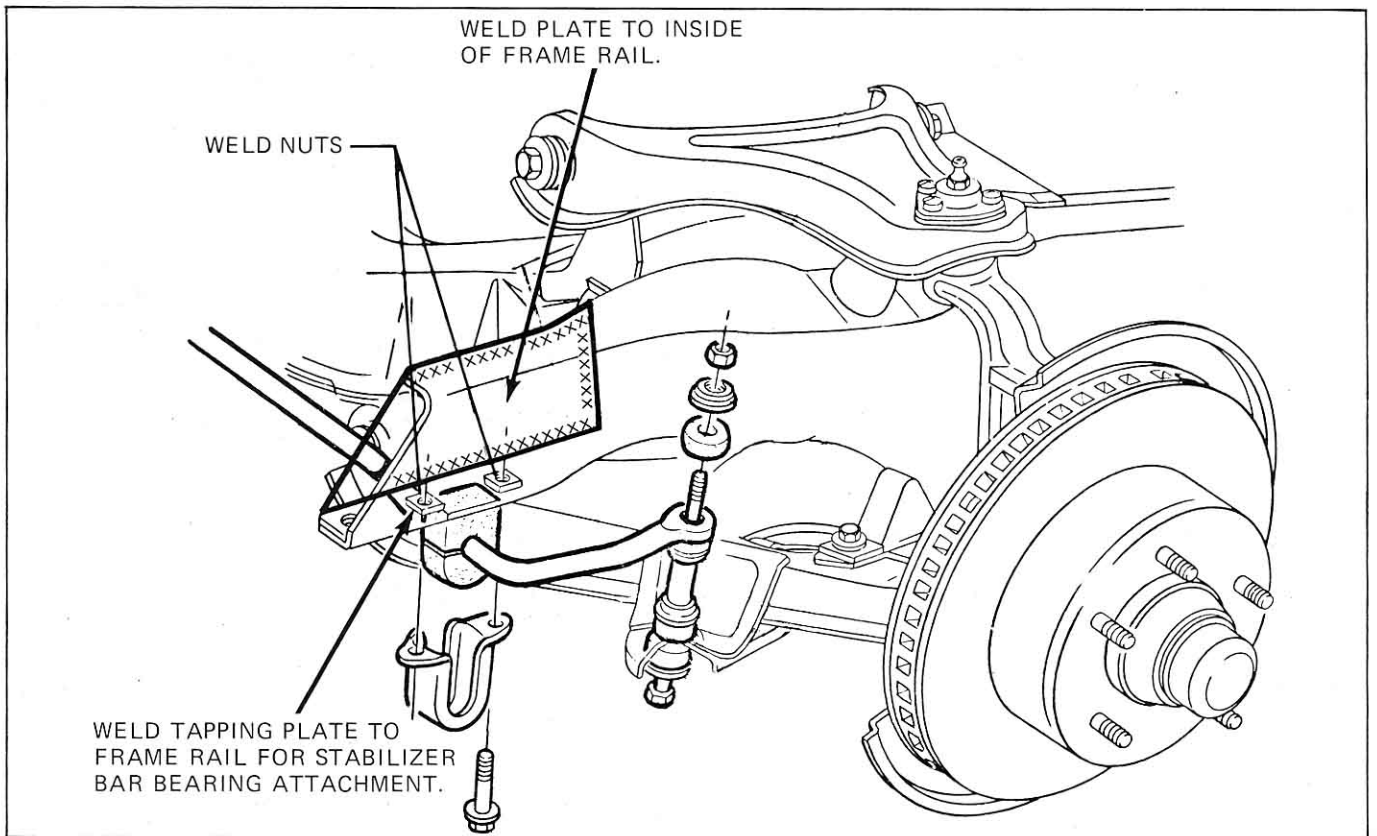

Figure 9 — Weld tapping plate to inside of frame rail for stabilizer bar bearing attachments.

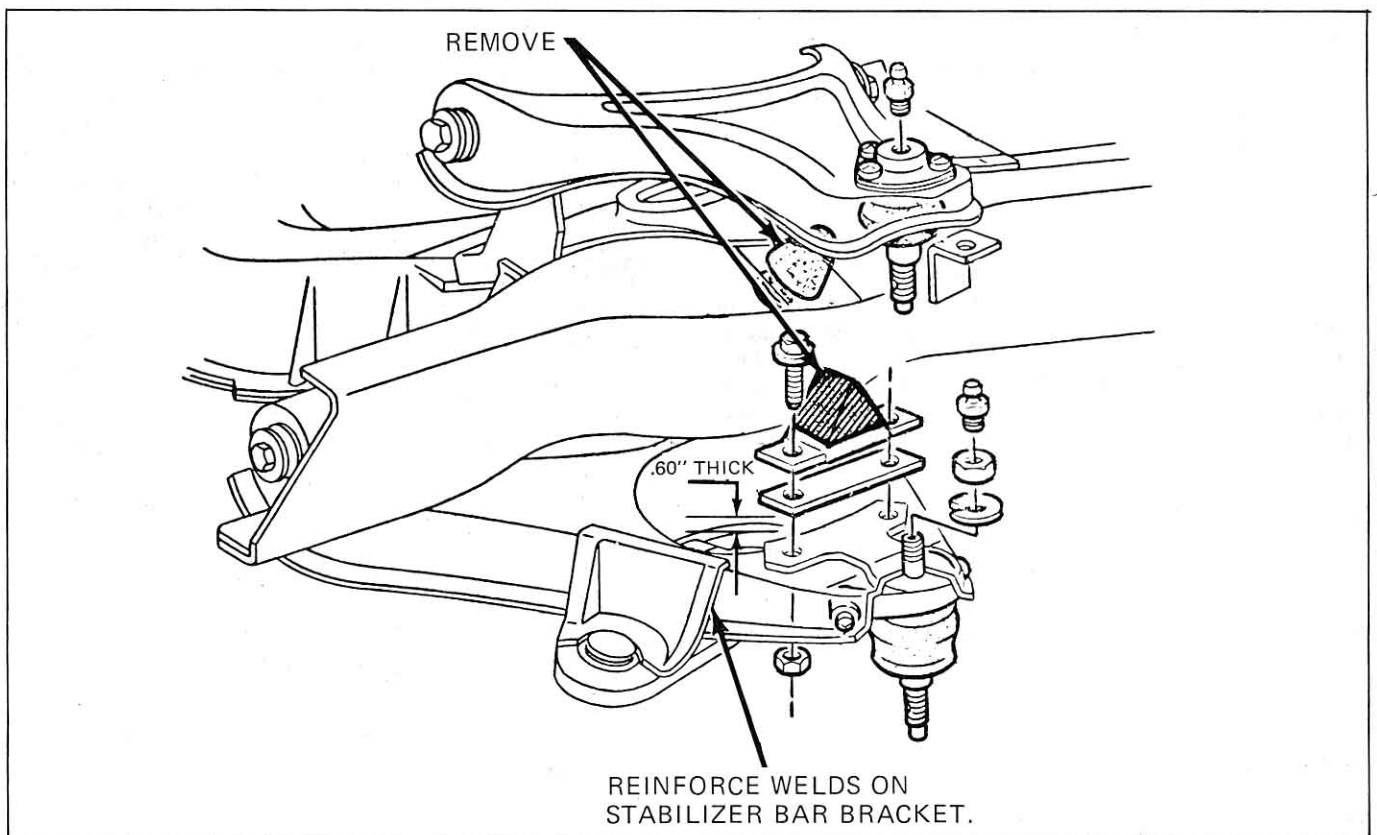

Figure 10 — Reinforce welds on stabilizer bar bracket and remove the upper /lower bumpers.

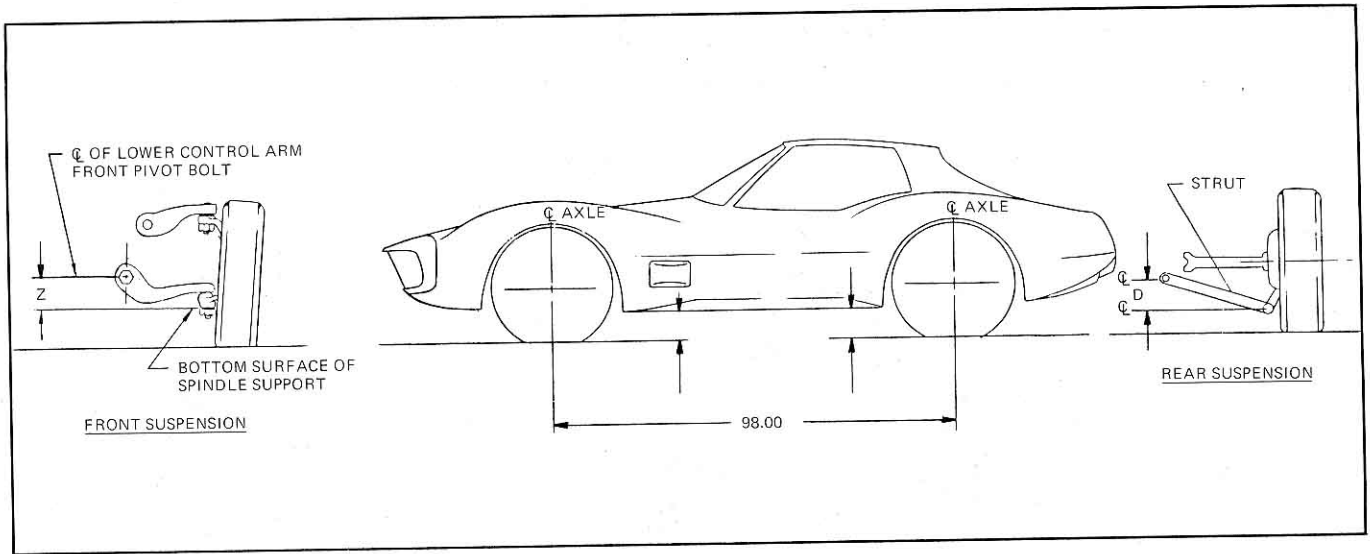

Figure 11 — Proper front and rear vehicle trim heights.

washers to prevent loss of shims if upper control arm shaft attaching bolts are loose.

Use 1969 or later production Corvette front spindle which incorporates the larger diameter wheel bearings. Adjust wheel bearing end play to .001 max. and use production high temperature type wheel bearing grease.

Trim rubber jounce bumper to metal-to-metal (*height .60 in.*) see Figure 10, page 4-5 or remove entirely if shock absorber and springs allow suspension travel to the point of control arm bottoming on the frame. Rebound control can be limited by means of shock absorber travel restriction or the application of an external stop in the form of metal-to-metal stop at upper control arm to frame contact point or a strap arrangement to lower control arm. Rebound should be limited to prevent the spring from unseating during its rebound travel. Spring usage should be F-41 front spring for applications on all tracks other than highly banked tracks. On high bank tracks, such as Daytona and Talladega, the "Daytona" front spring package should be used. Spring height should be adjusted by either bumping or bulldozing the spring to achieve a front "Z" height of 1-1/4 to 1-1/2" with the vehicle full of fuel and driver aboard. (Figure 11) This will provide adequate suspension travel while maintaining the lower front profile for aerodynamic use.

Stabilizer bar application can be production bars or bars similar to production manufactured by the individual. In all cases, they should be mounted on a solid bushing material such as aluminum, nylon, or delrin. The links at the end of the stabilizer bar connecting to the lower control arm should be replaced with rod end joints and a threaded shaft to provide noncompliant links and adjustable lengths.

It is desirable to check the "bump steer" of the front suspension to obtain zero toe change during the jounce portion of wheel travel. A production steering linkage setup may be adjusted by moving the inner tie rod pivot up approximately 1/2 inch. An area to watch is possible tire interference between the front tire and the steering arm and/or tie rod end.

When setting the vehicle up after build, the front wheel weights should be as near equal as possible without the stabilizer bar connected. Once the weight has been equalized with just the springs, the stabilizer bar should be attached and the links should be adjusted so there is zero preload of the front suspension due to stabilizer bar torsion.

## Rear Suspension

The differential carrier rear mounting crossbar rework was discussed in the frame preparation section. The rubber differential mounting insulators should be replaced by solid steel plates. The pinion nose front bushing should also be replaced by a solid metal bushing, preferably an aluminum block. Care should be taken to maintain the correct differential case attitude. If the plates have been moved up in the crossmember, this should be duplicated by adjusting the height of the aluminum block the same amount.

Rear suspension torque arms should be replaced with new units purchased from Service. The torque arms should have the parking brake cable mounting bracket removed and the surface ground smoothly. All seams should be completely welded to maintain total strength. The torque arm forward bushing can be replaced with a spherical joint if desired, although many cars run with the production rubber bushing.

It is desirable to install a threaded toe adjustment mechanism in place of the shim pack at the front bushing mounting point. If a threaded adjuster is not used, it is mandatory to use the late model shims which provide for a cotter pin to hold the shims in place. If tire clearance is required in the torque arm, it is mandatory the torque arm be fixtured before welding to maintain arm alignment. The torque arm section be maintained in the area of the offset and that all material added be of a thicker gage than production. (Figure 12)

Use rear spindle part number 3872476 which is a high nickel alloy forging and has proven satisfactory. Use a high



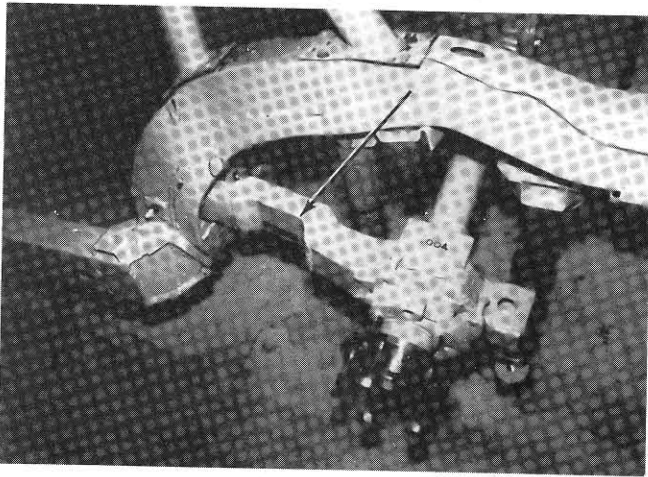

Figure 12 — Reworking rear suspension control arm.

pressure grease when building the spindle pack. Set spindle end play to .001" maximum. Delete all the parking brake and dust shield components in the rear spindle assembly as a weight saving measure and to provide additional brake cooling.

Use the current production 3" diameter axle driveshafts. These units came into production in 1975 and are serviced for all previous Corvettes. Use the cap type attachment instead of the strap type (cap part number 3872909), for attaching the axle to the yoke.

Rework strut rod attachment bracket on the bottom of the axle by welding a plate over the adjustment slot and drilling a single hole to accept rod end joint. Replace the strut rod with a threaded tube using left and right threaded rod end joints. This system provides a noncompliant link as well as positive camber adjustment and control. (Figure 13).

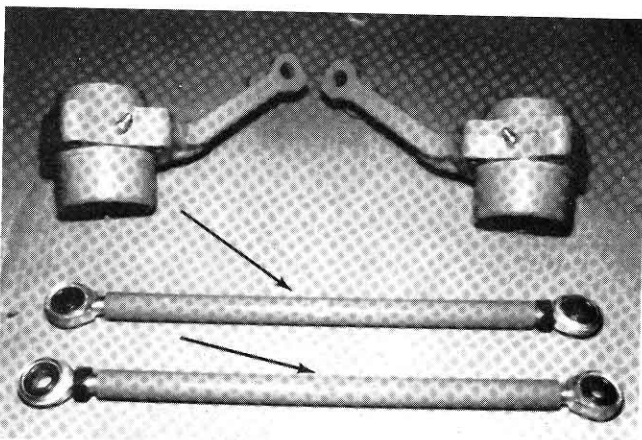

Figure 13 — Rear suspension strut rod replacement.

The lower strut rod attachment should be made with the Corvette heavy duty lower shock mounting pin in place of the production unit. Part number of the heavy duty pin is 3829265-66. Use the F-41 rear spring for normal track surfaces. For high bank tracks such as Daytona and Talladega,

use the "Daytona" spring package. When installing the spring, use longer spring hanger bolts made out of high strength steel to provide a means of height adjustment. Set the rear "D" height to 1-1/4" with fuel and driver aboard, as shown on Figure 11.

The use of longer spring bolts allows the adjustment of weight from side to side to equalize corner loads. Trim the rear jounce bumpers to approx. .60" thickness which provides maximum suspension travel while preventing the universal joints from bottoming out during full bump. If the axle has been moved up in the frame, it may be possible to remove the jounce bumpers entirely. Before this is done, a static check should be made in full jounce position to determine if the universal joints are grounding out. Rebound control should also be checked to make sure universal joints do not ground out in full rebound.

Production rebound control is maintained by shock absorber length. If replacement shock absorbers are used, a check should be made at full rebound to assure universal joints are not grounding out. If the shock cannot do this, a strap or cable should be provided between the control arm and the frame to prevent excessive rebound travel. The production type rear stabilizer bar is satisfactory if the links from the control arm to the stabilizer bar are replaced with rod end joints and threaded shafts to allow adjustment. When installing the bar (Figure 14, page 4-8), make sure the linkage is such that the stabilizer bar will not travel to an "over center" condition in full rebound. It may be necessary to lower the axis of the bar to prevent this.

The F-41 rear spring and the recommended front bar should be used with a 3/4" dia. rear bar. This diameter bar will have to be fabricated to the standard production bar configuration. Care must be taken to provide adequate tire clearance when forming the bar. The "Daytona" spring with recommended front bar can use either a 9/16 production rear bar or possibly a 5/8", depending upon vehicle. It may be necessary to alter these bar diameters slightly to provide the correct balance depending on the individual car and driver preference. In any case, stabilizer mounting bushings to frame should be replaced with a solid material such as delrin, nylon, bronze, aluminum.

It is desirable to replace the shock absorbers with external double adjustable shock absorbers. The early F-41 Corvette heavy duty shocks may also be used. This is a large diameter shock which increases rebound and jounce damping over the standard shock and has greater heat capacity.

## CLUTCH AND TRANSMISSION PREPARATION

The following procedures should be followed to insure minimum difficulties and maximum durability from the heavy duty Chevrolet clutch and transmission components.

### Clutch

1. The crankshaft pilot bushing should be replaced if the original bushing shows an eccentricity or wear.

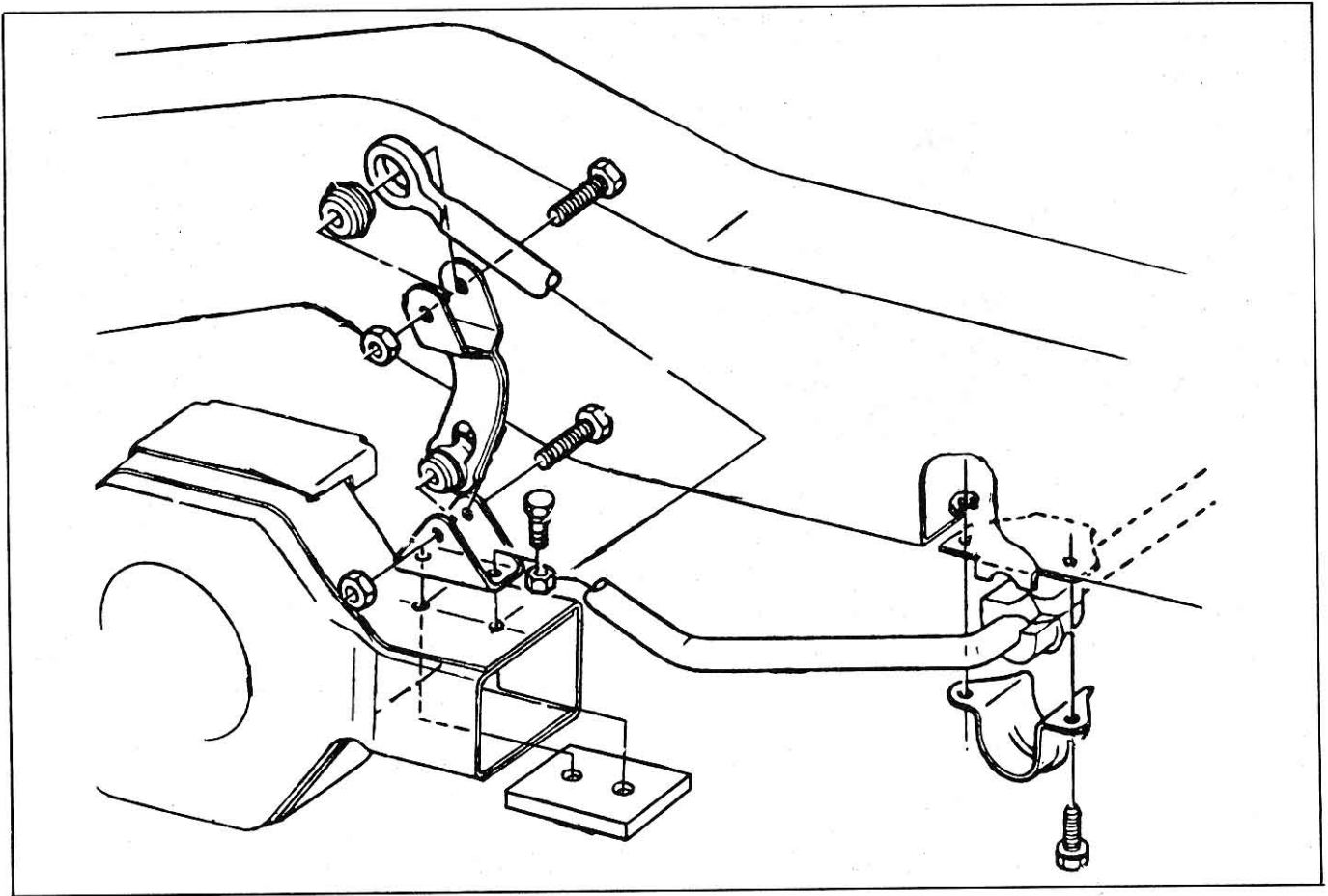

Figure 14 — Rear stabilizer bar installation.

2. The clutch housing transmission mounting face must be parallel to the crankshaft flywheel mounting face or the rear face of the clutch housing should be machined to obtain parallelism.

3. The clutch housing pilot hole for the transmission bearing retainer must be concentric to the crankshaft centerline. Offset dowel pins are available to adjust the concentricity.

The following clutch components have proven to be satisfactory during high performance usage:

1. RPO L-88 nodular cast iron light weight 12-3/4" diameter flywheel (P/N) 3991406).

2. Clutch cover and pressure plate (P/N 6273958) using a nodular iron pressure plate, flat drive strap, higher release load spring and nominal 3200 lb. pressure plate load.

3. Clutch driven plate (P/N 3991428) using a bonded aluminum backed clutch facing, heavy duty splined hub and low height cushion springs.

The clutch driven plate should be checked for any burrs or roughness on the hub splines which might impede movement on the transmission input shaft. It is advisable to "lap" the clutch disc on the clutch gear to remove any burrs.

(Figure 15) The clutch driven plate requires a break-in period to remove friction material "fuzz" which will cause the clutch to release incompletely.

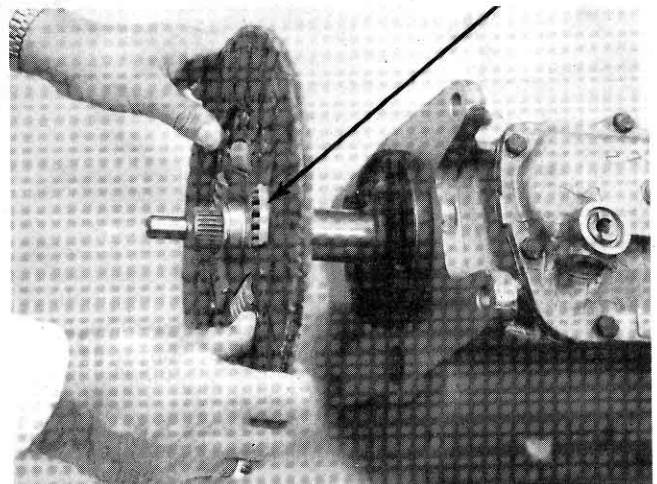

Figure 15 — Lapping the clutch disc on the clutch gear to remove any burrs.

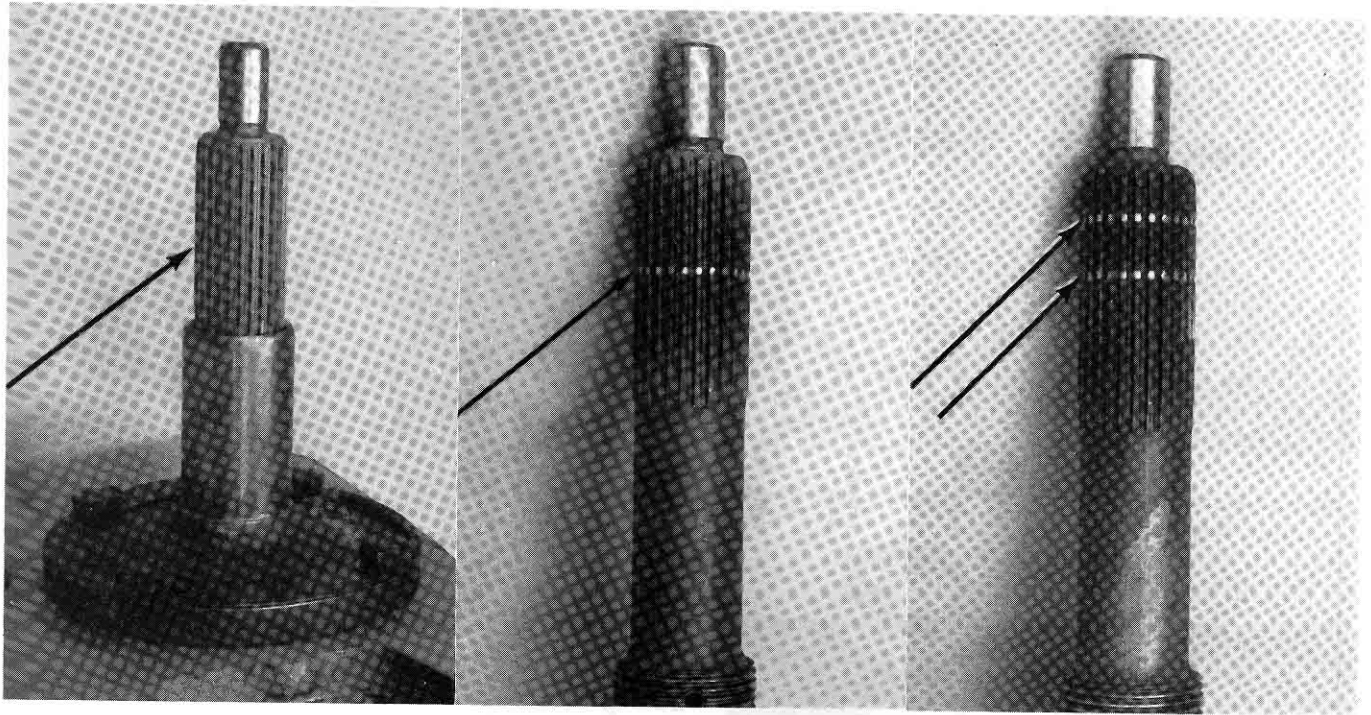

Figure 16 — Illustrated transmission identifying the circumferential grooves on input shaft.

## Transmission

The Chevrolet Muncie transmission using a cast aluminum gear case and extension housing is the most durable 4 speed manual transmission offered by Chevrolet for high performance usage. The close ratio Muncie transmission with 2.20:1 first gear ratio, 26 spline input shaft and 32 spline output shaft is recommended for off-the-highway road racing activities. There are three aluminum case Muncie transmissions which may be identified as follows:

1. Heavy Duty Performance (Close Ratio) transmission uses low helix angle gear set, close ratio gears with 2.20:1 first gear, oil drain plug on gear case and no identifying circumferential grooves on input shaft. (Figure 16)
2. Standard Performance Transmission has close ratio gears with 2.20:1 first gear, no oil drain plug on gear case and one circumferential groove on input shaft.
3. Regular Four-Speed Transmission has wide ratio gears with 2.52:1 first gear, no oil drain plug and two grooves on input shaft.

The following special steps should be followed before any transmission is used in competition:

1. Transmission should be thoroughly disassembled for visual inspection as well as magnetic particle and dye penetrant inspection of all components. (Figure 17, page 4-10)
2. Nut or grit blast inside of case to remove casting sand and casting flash.
3. Polish front and rear surfaces of counter gear. (Figure 18, page 4-11)

4. All synchronizer (blocker) rings should be checked for hardness ( $R_B$  75-80 preferred) and checked for roundness either with a dial indicator or with "Prussian Blue" against a cone. (Figure 19, page 4-11)

The blocker ring thread flats should be .002" - .004" wide which can be checked with an optical scale. All burrs should be removed from the blocking ring chamfers. Add six (6) wiping grooves or slots to inside of diameter of blocker ring using a jewelers file. (Figure 20, page 4-11)

Use only blocker rings with small "B" imprinted on face of ring at small end of cone. (Figure 21, page 4-11)

5. Bend tang of counter gear thrust washer to approximately 90° without cracking tang to prevent rotation of washer against case. (Figure 22, page 4-12)

6. Measure run out of counter gear rear thrust surface in case and do not use case if run out exceeds .005". (Figure 23, page 4-12)

7. Special first gear roller bearing unit (P/N 326576) consisting of reworked 1st gear, special thrust washers and needle bearing is suggested in place of the production 1st gear. (Figure 24, page 4-12)

8. Use 20 lb. side cover detent spring (P/N 3831718). Install TCS switch plug (P/N 3906448) and gasket (P/N 3906462).

9. D-A gear lubricant or similar high quality lubricant should be used on all running surfaces during assembly. Use magnetic fill and drain plugs.







Figure 18 — Polishing front and rear surfaces of counter gear.

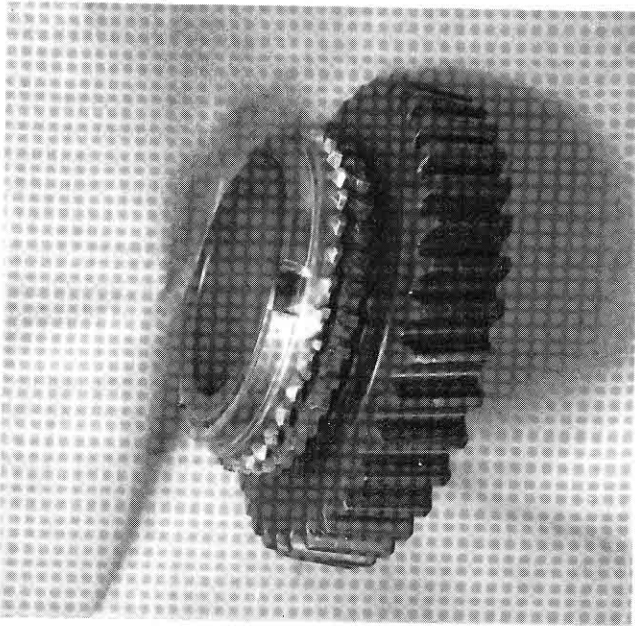

Figure 19 — Cone and blocker ring referenced in Step 4.

10. Run transmission on spin test rig if possible to insure burnish of gears and proper seating of blocker rings. After transmission oil is warmed up, shift through all forward gears, slowly at first, then progressively faster.

11. Transmission side cover bolts, drain and fill plugs and clutch housing attaching bolts should all be safety wired.

12. Some competitors use a transmission oil cooler for long distance events but may not be necessary if the

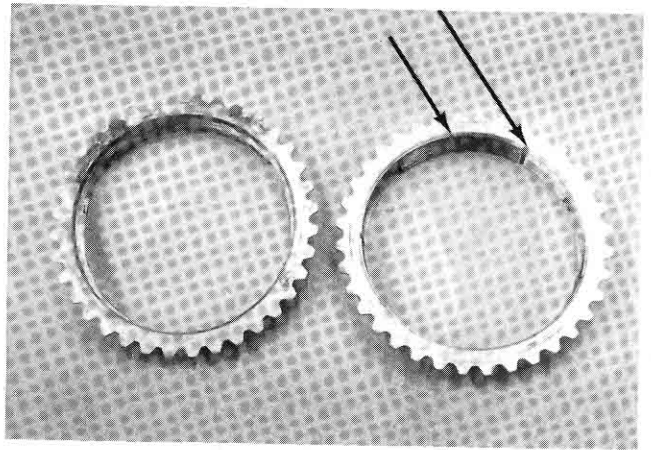

Figure 20 — Blocker ring comparison showing wiping grooves or slot modifications.

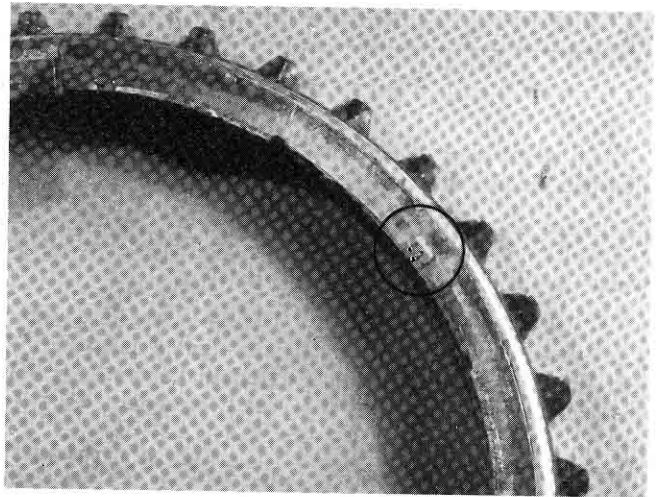

Figure 21 — Blocker ring with small "B" imprinted on ring at small end of cone.

transmission lubricant temperature does not exceed 275° - 290°F.

## REAR AXLE AND DIFFERENTIAL

The Corvette rear axle has proven to be satisfactory for high performance applications if prescribed inspection and assembly techniques are followed.

The differential should be completely disassembled for visual and magnetic particle inspection especially for heat treatment cracks in the large or "loading" window of the differential case. Grind the edges of this large opening to a smooth contour and shotpeen this surface (Figure 25, page 4-13)

The latest released differential cases P/N 3997926 for gear ratio 2.70:1 to 3.70:1 and 3997928 for gear ratio 3.90:1 to

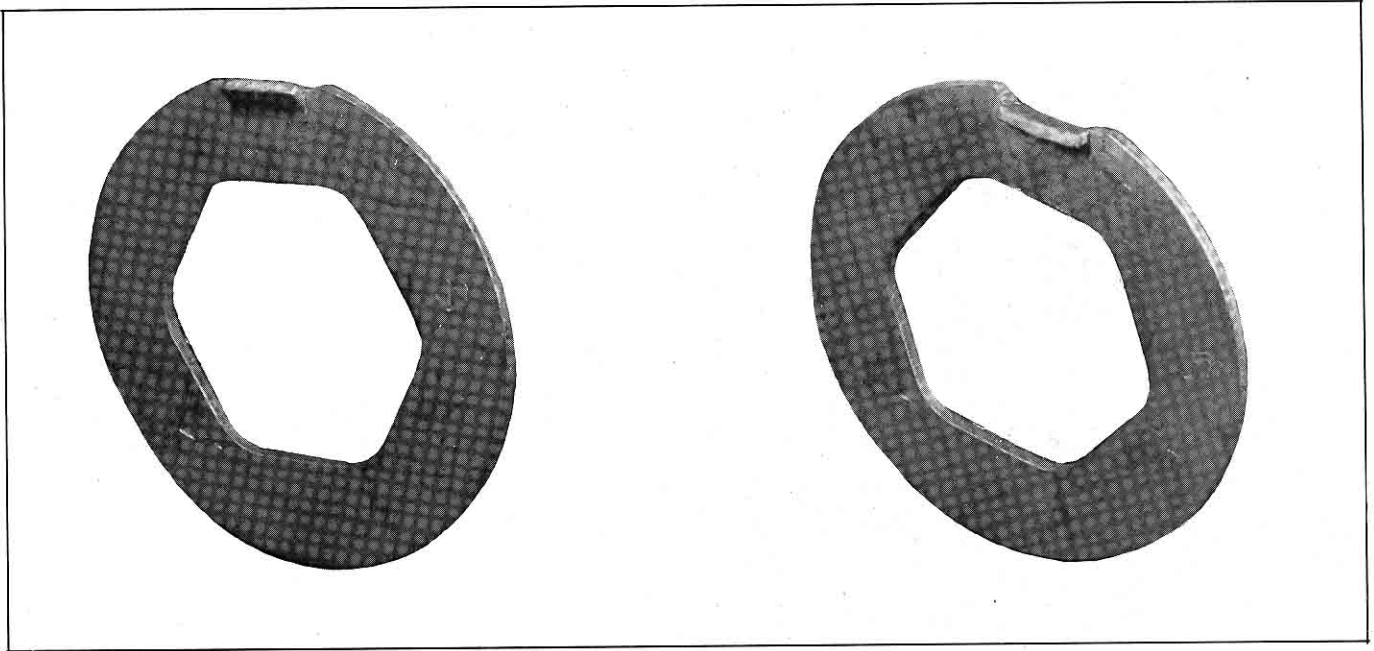

Figure 22 — Comparison of a stock washer and a washer with the desired 90° bend.

5.11:1 which have higher hardness cases should be used for all rear axle rebuilds.

Use heavy duty limited slip kit (P/N 3982240) consisting of 22 friction plates, higher load springs, thicker spring load plate and shot peened differential gears.

“Loctite bearing retainer” should be used to secure the inner and outer raceways of the differential case bearings: Production ring gear bolts and differential bearing cap bolts should also use “Loctite” stud lock compound.

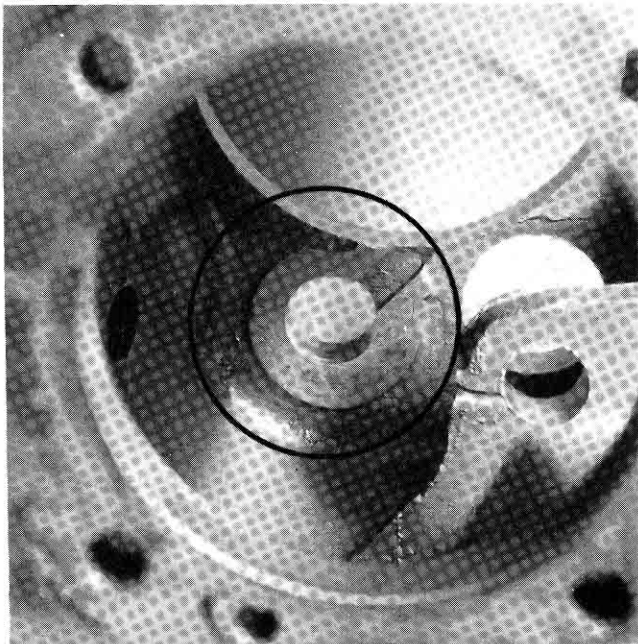

Figure 23 — Counter gear rear thrust surface.

Pinion bearing preload should be set to 8 to 12 in.-lb. and differential bearing preload should be 13 to 15 in.-lb. The differential torque value is divided by the axle ratio when measuring total preload at the pinion.

Use pinion flange (P/N 3878972) which accepts 2-1/4" OD propshaft assembly (P/N 3921675). Maximum run-out of pinion flange is .005" T.I.R. with zero run out desirable for high speed smoothness. Polish and prelube pinion seal contact surface.

Use axle output or drive yoke (P/N 3872922) which is cap type used on all large block vehicles. The yoke end play must be reduced to less than .005" using shims provided in yoke kit.

Use magnetic plug (P/N 2309473) in filler hole and install steel vent (P/N 1171317) in rear cover. D-A rear axle lubri-

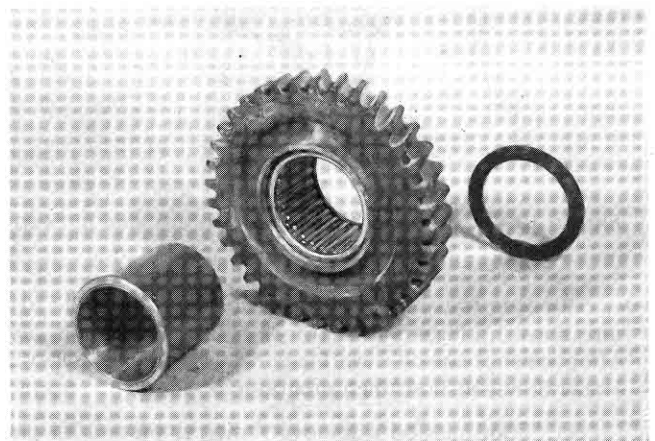

Figure 24 — Rework 1st gear, special thrust washer and needle bearing.



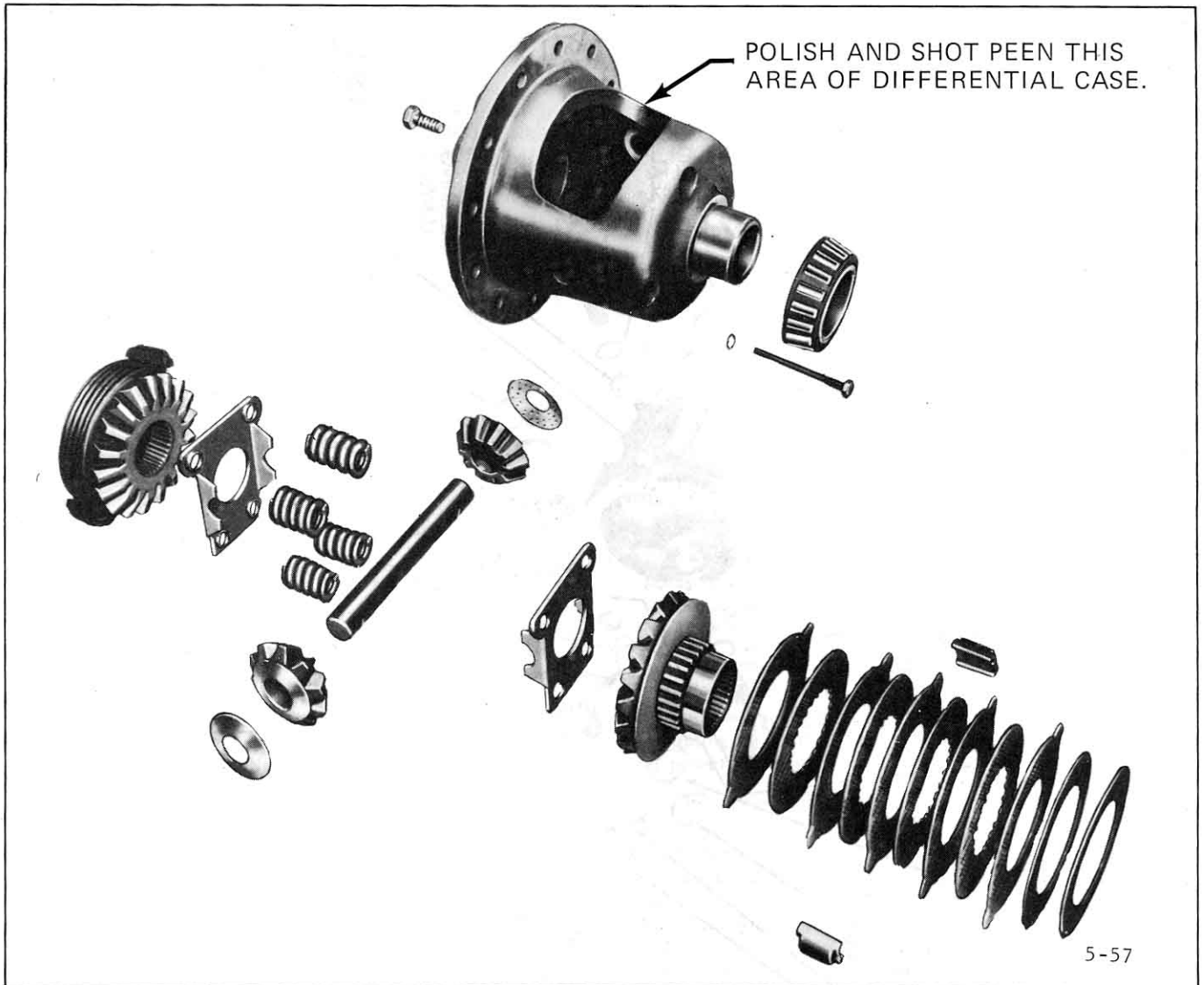

Figure 25 — Exploded view of Corvette positraction.

cant or other high quality lubricant should be used during build-up and for running.

Gear and bearing break-in on a test stand is recommended consisting of a minimum of two (2) hours running at 1000 to 2000 RPM. The initial break-in oil should be drained and refilled for operation.

A rear axle cooler is suggested for any endurance events. Harrison oil cooler (P/N 3157804) and electric driven circulation pump such as Jabsco #6360 are frequently used by competitors. The cooler should be mounted at about the same height as the differential so the axle will not overflow in case of circulation pump failure.

Axle rear cover may be reworked for cooler lines by drilling and tapping on vertical line 3/4" to left of centerline of middle vertical rib, the top hole down 1.28" from crossmember surface and the bottom hole up 1.46" from spring surface. Tap for 1/2" pipe thread and install fittings with thread lock, grind off fittings flush with inside of cover.

Lower bushing should have bottom edge of inlet rounded for oil pickup. Cooled oil enters axle through top bushing to spray on ring gear and pinion bearing.

## SUGGESTED CHEVROLET SERVICE PARTS:

NOTE: See Figure 26, page 4-14) for proper parts identification.

### 1. Differential Carrier Assembly (with ring & pinion)

3.08	3899132
3.70	3899137
4.11	3899139
4.56	3899141
—	3917861*

\*Without Ring & Pinion

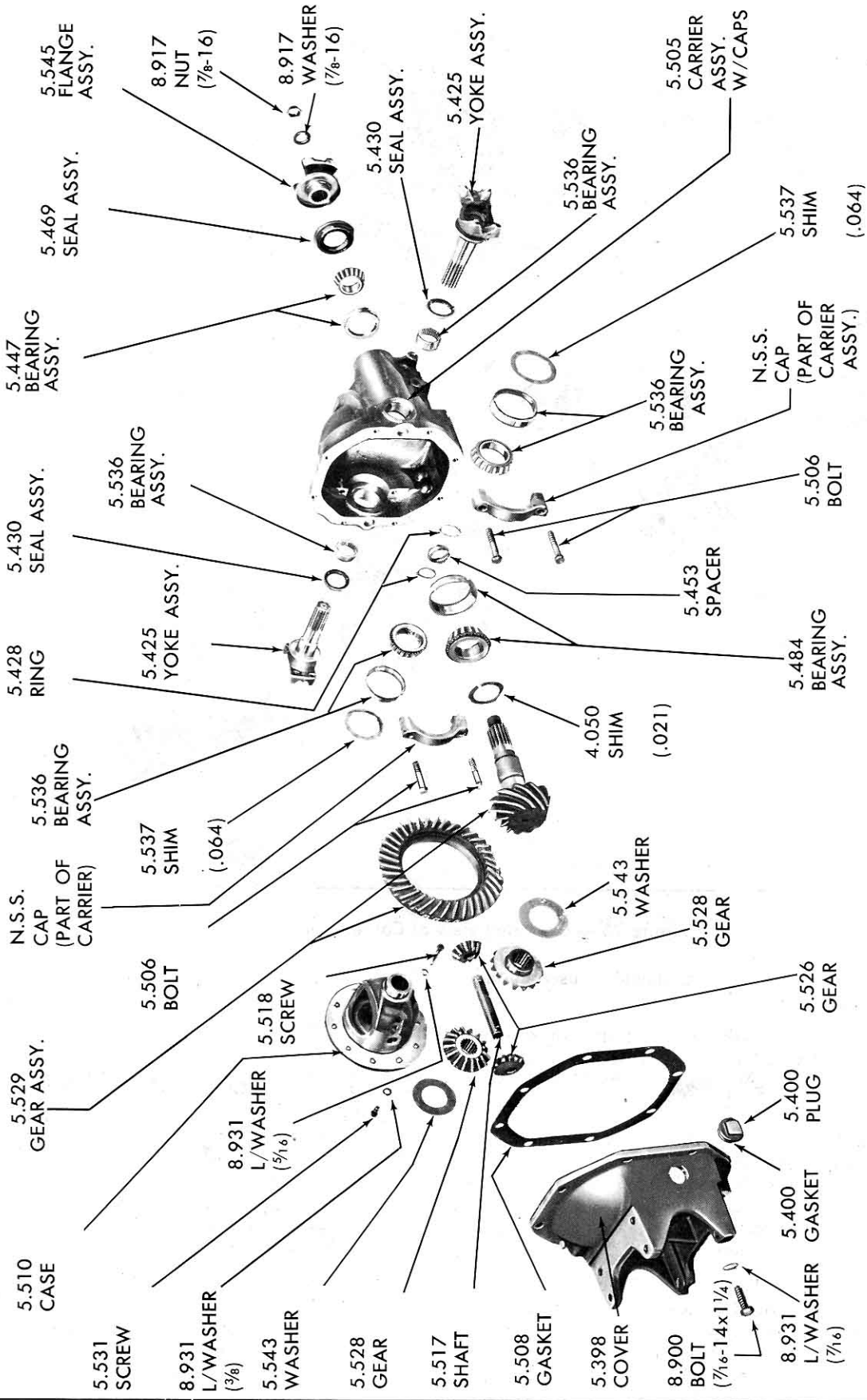

Figure 26 — Corvette Rear Axle Carrier Assembly — Exploded.

2. Ring and Pinion Gear Set

Ratio	Unit Part No.	Ring/Pinion
2.73	3961431	(41/15T)
2.92	341301	(41/14T)
3.08	3961418	(37/12T)
3.36	3961423	(37/11T)
3.55	3961420	(32/9T)
3.70	3961419	(37/12T)
3.90	3970551	(39/10T)
4.11	3961421	(37/9T)
4.56	3961424	(41/9T)
4.88	3963840	(39/8T)
5.14	3970552	(36/7T)

3. Differential Case

Ratio	Part No.
All up to & incl. 3.70	3997926
4.11	
4.56	3997928
3.90	

4. Bearing Asm.

	Assy. No.
Diff. Side (Timken No.)	7451140
Frt. Pinion (Timken No.)	7450984
Rear Pinion (Timken No.)	7451155

5. Miscellaneous

Pinion Seal (Viton)	3982239
Pinion Flange	3879208
Diff. Conversion Kit (H.D.)	3982240
Fill Plug (Magnetic)	2309473
Drain Plug	
Vent	3820840
Oil Cooler Line Fittings (if applicable)	3220X8X6 (Weatherhead No.)

6. Recommended Bolt Torques

Ring Gear to Differential Case Bolts	40-60 lbs. ft.
Cover to Differential Carrier	35-55 lbs. ft.
Differential Cap to Carrier	50-60 lbs. ft.

**BRAKE SYSTEM**

The braking system is one of the main component systems on a vehicle and its proper operation is imperative to the performance of a competitive car.

There are three basic areas to the brake system: First is the correct mechanical components, second is a proper

hydraulic system and bleed, and third is adequate cooling.

**Components**

Chevrolet services a complete heavy duty brake system for the Corvette consisting of heavy duty front caliper assemblies, supports and heavy duty pads. The rear uses heavy duty pads in the existing caliper assemblies. When selecting the components for the system, a decision as to whether to use a manual brake system or a power boost system should be made. The manual brake system is generally a more responsive system but has a penalty of higher pedal effort. If a Chevrolet vacuum power boost unit is used, the noise attenuator (filter) packing around the push rod opening should be removed to improve the response time of the diaphragm during pedal application.

The production Corvette master cylinder or a similar 1-1/8" diameter master cylinder with a larger reservoir capacity can be used. An early Chevelle service master has a similar bore but larger capacity. The increased capacity insures adequate fluid for use with worn pads, such as might be encountered in a long distance race. A replacement master cylinder with 1-1/4" diameter piston can be adapted to provide increased hydraulic fluid displacement if a progressive loss of pedal height is encountered during an endurance event. These larger diameter master cylinders are used on 1974 or 75, 20 and 30 series Chevrolet trucks.

Extreme care should be taken to adjust the master cylinder push rod so the piston fully returns to rearward position when the brakes are released. The master cylinder mounting holes must also be slotted to attach to the firewall or power brake booster.

If a replacement master cylinder is used, care should be taken to remove the pressure reserve valve in the rear circuit if the master is from a disc drum type braking system. When installing the master cylinder in the car, care should be taken to insure a full stroke in the master before the pedal bottoms out of the toe pan. If this is not happening, lengthen the push rod to insure the piston bottoming out in the master cylinder bore prior to the pedal hitting the floor.

All flexible brake lines should be replaced with new production lines or with Aeroquip brand steel flexible lines. This is done in order to minimize volume change due to hose expansion during pressure applications.

When installing the rotors and caliper assemblies on the vehicle, the rotor should be centered in the caliper housing. If the production rotor and the spindle do not give this condition, then shim the rotor or caliper mount to position the rotor in the center of the caliper housing. It is useful to polish the forward edge of the opening in the caliper housing and the leading edge of the brake shoes to a smooth finish and apply a lubricant such as Molycote to reduce the friction between the pad and caliper housing during brake application.

**Hydraulics**

The second phase of the brake area is the bleeding of the hydraulic system. It is very essential that all the air be removed from the system in order to maintain a firm pedal under all braking applications. The most important item to remember during bleeding a brake system is to use clean, new brake fluid since brake fluid will absorb moisture from

the air which reduces the boiling point. Either a high temperature glycolbase brake fluid or a low viscosity silicone based brake fluid are acceptable. In either case, care should be taken when pouring the fluid into the master cylinder to prevent the formation of small bubbles which can become trapped in the system. When bleeding, either by pressure bleed system or by manually stroking the brake pedal, tap the caliper housings with a small rubber hammer to free-up any lodged air bubbles that may get caught in the calipers. Use sufficient fluid to purge the system completely and insure complete elimination of any air bubbles.

## Ventilation

The final facet of building a brake system is to provide

## CORVETTE CHASSIS MODIFICATIONS

These specifications are intended to provide guidance in modifying a Corvette chassis and suspension for use in limited off-road gymkhana or solo slolem events. The resultant highway ride will be noticeably harsher than a production Corvette but steering response and handling will be more suitable for off-highway activities.

Chevrolet currently offers a production option RPO FE7 for the Corvette which consists of larger diameter front and rear stabilizer bars (sway bars) and higher rate (stiffer) front and rear springs.

Following is a comparison of the standard Corvette and RPO FE7 chassis components:

	Standard	1973-74 RPO FE7	1975 RPO FE7
Front Stabilizer Bar Part #	334930	3831972	351596
Front Stabilizer Bar Diameter	13/16"	15/16"	1-1/8"
Front Stabilizer Bar Bushings (2)	3923674	3923674	351593
Rear Stabilizer Bar Part #	—	3967713	351597
Rear Stabilizer Bar Diameter	—	.562"	.44"
Rear Stabilizer Bar Bushing (2)	—	480912	351600

In addition, the following front stabilizer bars are available for optimum chassis tuning.

Part Number	Bar Dia. (In.)
3831971	3/4
334930	13/16
3871318	7/8
3831972	15/16
351596	1-1/8

Stabilizer bar bushings must be fabricated for the above optional diameter bars.

adequate ventilation for the rotors. This translates into having effective air ducts to direct cooling air to the brake rotors. In the front, pull the air from the front spoiler assembly ducting it through 3" hose to the center of the rotor. The air being ducted to the center will be pumped through the vanes of the rotor by centrifugal force and provide cooling over all of the surface area of the rotor. It may be useful to direct a stream of cooling air to the surface of the rotor itself.

Ducts may be used in the rear if required. The ducting need not be as elaborate in the rear as it is in the front. This would depend upon vehicle application and drivers use of the brakes.

The following chassis springs are also available:

	Part Number	Rate #/In.
Production Front	346939	280
RPO F41 Front	3832518	550*
"Daytona" Front	3986032	860*

\*Lower vehicle approximately one inch.

	Part Number	Rate #/In.
Production Rear	3850839*	140
F-41 Rear	3828811**	305
"Daytona" Rear	6258056	450

\*Part of unit P/N 356825

\*\*Part of unit P/N 3977578.

Suggested initial suspension geometry settings for the Corvette are:

Front and Rear Camber	$-1^{\circ} \pm 1/2^{\circ}$
Front Caster	$+1^{\circ} \pm 1/2^{\circ}$
Toe in (Total)	$1/16" \pm 1/32"$

Optimum front and rear suspension settings are normally determined by tire tread wear patterns and by measuring the operating temperature profile if a tire pyrometer is available. Manufacturers recommendations should be followed for tire inflation pressure.

Multi-position adjustable shock absorbers available from several after-market suppliers are generally recommended. Clearance between optional shock absorbers and suspension coil springs and spring tower should be carefully checked during full wheel travel. Spring tower modification and bump rubber rework for Koni shock absorber clearance as shown.

HEAVY DUTY SUSPENSION INSTRUCTION SHEET  
CORVETTE

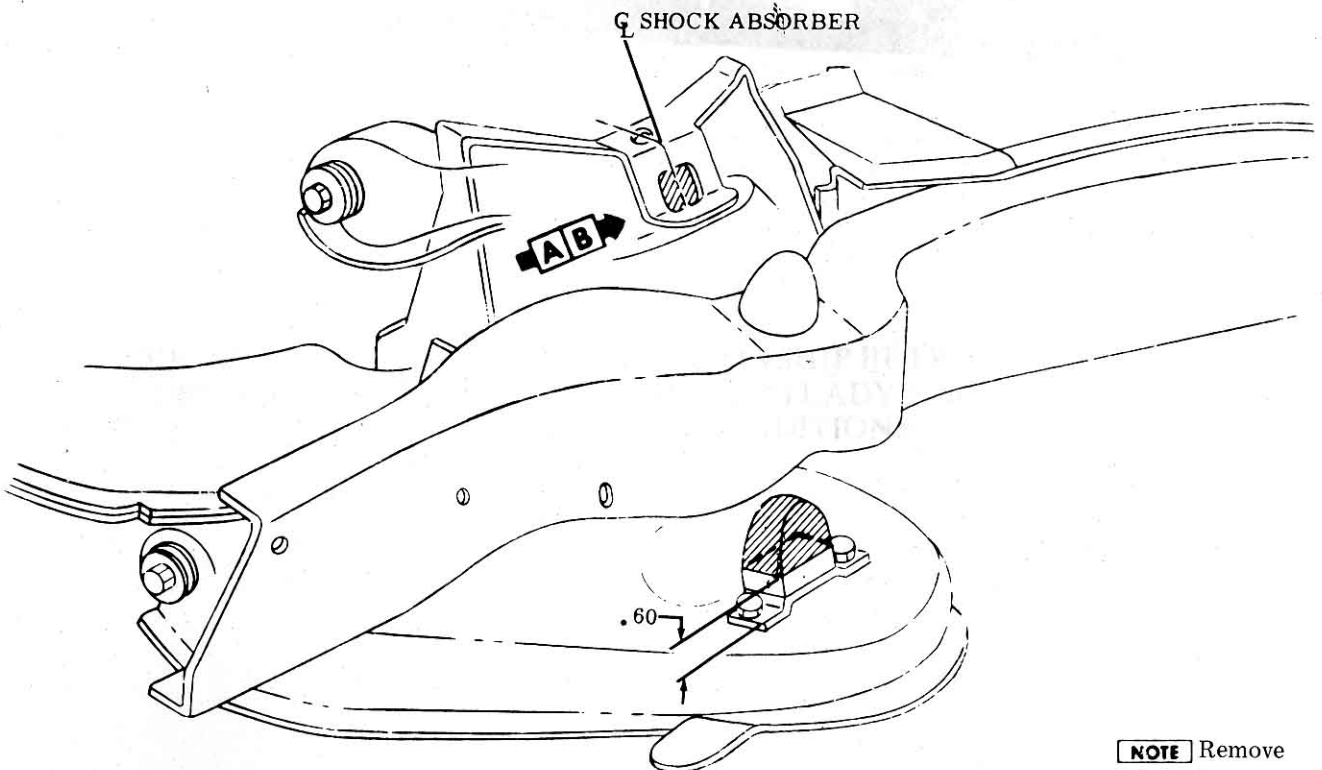
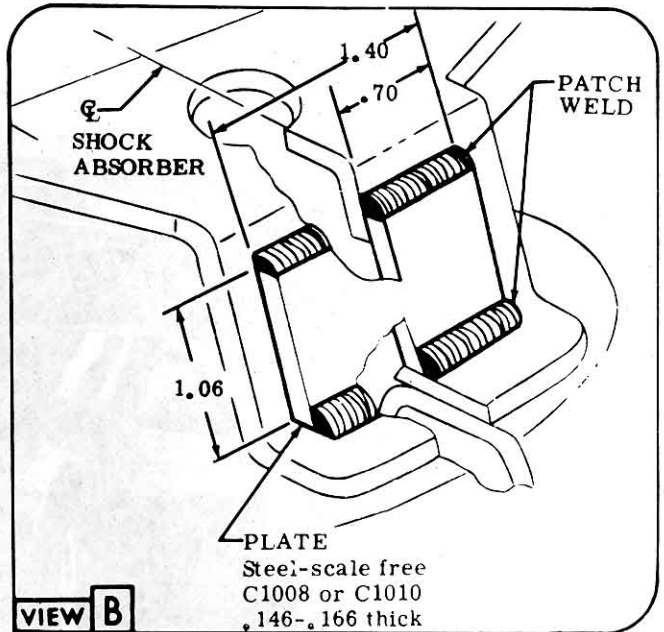
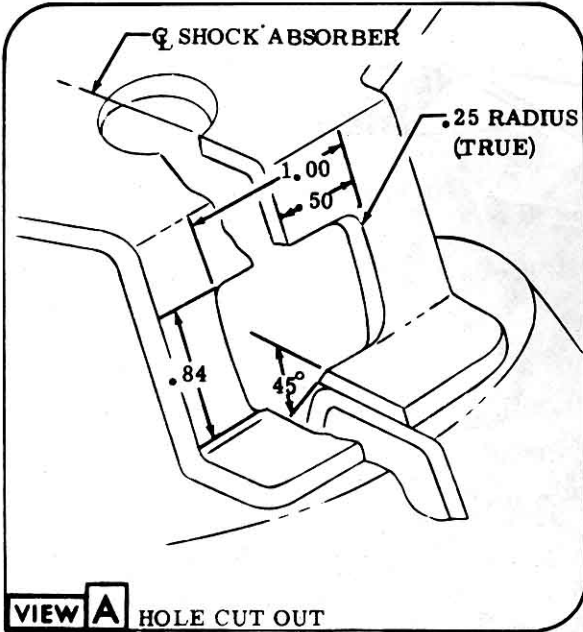

**SHOCK CLEARANCE REWORK**

SEE SHOP MANUAL FOR REMOVAL AND INSTALLATION OF SHOCKS AND SPRINGS.

Figure 27